

MOTOR GRADER

GD521A-1

FLYWHEEL HORSEPOWER: 135 HP **101 kW** @2500 RPM
OPERATING WEIGHT: 10800 kg **23,810 lb**



Engine side covers, front hydraulic piping covers, and rear side covers are optionally available. Model shown may include other optional equipment.

KOMATSU: The Quality is Standard.

- Sturdily-built main frame and tough power train make it easy to complete heavy-duty jobs.
- The performance-proven Komatsu S6D105 diesel engine delivers a healthy 135 HP (101 kW), more than enough for the most difficult of tasks.
- A non-spin differential with automatic locking and unlocking can be installed as an option on the single reduction final drives, assuring the optimum in smooth steering.
- Tough efficient hydraulic system makes best use of every part of the machine.
- Wide blade range and frame articulation make this machine ready for a real variety of diverse operations.
- Ideal weight distribution makes it possible to dig harder ground with excellent machine stability.
- Because of its combination of blade sideshifting and frame articulation, the GD521A can assume a wide variety of operating positions.
- Operator's compartment is mounted on rear frame, giving the driver excellent visibility and ease of operation.

KOMATSU

SPECIFICATIONS



ENGINE

Komatsu S6D105, 4-cycle, water-cooled, overhead-valve, turbocharged diesel engine of 6 cylinders with 105 mm (4.13") bore × 125 mm (4.92") stroke and 6.49 ltr. (396 cu.in) piston displacement.

Flywheel horsepower:

135 HP (101 kW) at 2500 RPM (SAE J1349)

137 PS (101 kW) at 2500 RPM (DIN 6270 NET)

Direct-injection for fuel economy. Mechanical all-speed governor. Gear pump-driven force lubrication with full-flow filter. Dry-type air cleaner with automatic dust evacuator, precleaner and dust indicator for extended element service intervals. 24 V/5.5 kW electrical starting motor. 24 V/25 A alternator. 2 × 12 V/110 Ah batteries.



HYDROSHIFT TRANSMISSION

The Komatsu HYDROSHIFT transmission consists of planetary gears and hydraulically actuated and force-lubricated multiple-disc clutches, assuring light-touch, effort-minimizing shifting. Both speed shifting and direction changes are completed by a single lever. With the inching pedal, precise finishing operation and smooth machine starts are ensured. A super wide range of 6 forward and 6 reverse speeds match all job requirements. Accidental machine starts are prevented by a gearshift lock device and engine starts only when the shift lever is set in the neutral position.

Travel speeds (at rated engine RPM)

Forward	1st	2nd	3rd	4th	5th	6th
km/h	3.4	6.1	10.8	14.2	25.5	44.6
(MPH)	(2.1)	(3.8)	(6.7)	(8.8)	(15.8)	(27.7)
Reverse						
km/h	4.2	7.5	13.1	17.3	31.1	54.4
(MPH)	(2.6)	(4.7)	(8.1)	(10.8)	(19.3)	(33.8)

Max. drawbar pull 6140 kg (13,535 lb/60.2 kN)



FINAL DRIVE

Spiral bevel gear reduction final drive. Roller-chain tandem drives for four rear wheels. Tandem case swings up to 13°, assuring high machine stability and positive traction during operation.



AXLES

Front axle: Reverse Elliot-type front axle with a center ground clearance of 610 mm (2') and oscillation angle of 32° (total) assures stable machine travel. Hydraulic front wheel leaning (20° to each side).

Rear axle: Full-floating rear axle is made of forged heat-treated steel.



WHEELS

Front and rear tires 13.00-24-8PR (G-2) traction-type tubed tires
Rims 8.00TG × 24 (SDC)
Inflation pressure 1.8 kg/cm² (25.6 PSI/177 kPa)



STEERING

Full-hydraulic orbitrol type steering control system with one steering cylinder is directly actuated on the knuckle arm. Maximum steering angle of front wheels is 49° left and right.

Frame articulation angle 27°, left and right
Min. turning radius (frame articulated) 6.6 m (21'8")



BRAKES

Service brakes: Foot-operated, hydraulically actuate internal expanding type on 4 rear wheels, hydraulic booster for sure braking.

Parking brake: Mechanical, internal expanding type actuated on transmission shaft.



FRAMES

Frames are articulated by two hydraulic cylinders. Box-sectioned front frame is steel-plate-welded constructed. One-piece-frame design for the front frame on which hydraulic pipings are installed offers excellent front visibility for more precise operations.

Front frames section (width × height) 280 × 294 mm
(11.0" × 11.6")



BLADE EQUIPMENT

Drawbar: A-shaped, U-section press-formed and welded construction for maximum strength.

Circle: Hydraulically controlled, internal gear type circle with four guide shoes for smooth 360° rotation.

Circle diameter (outer) 1300 mm (4'3")

Moldboard: Box-section constructed with wear-resistant steel. Hydraulic blade sideshift and manual tip control. Reversible end bits are attached.

Length × height × thickness 3710 × 645 × 19 mm
(12'2" × 2'1" × 0.75")

Blade base 2540 mm (8'4")

Blade load 5585 kg (12,310 lb/54.8 kN)

Cutting edges: Curved type cutting edges meet SAE standard J739b.

No. of cutting edges 2

Length × height × thickness 1829 × 152 × 16 mm
(6' × 6" × 0.63")



BLADE RANGE

All blade movements and position can be hydraulically controlled from the operator's seat.

Max. lift above ground 450 mm (1'6")

Max. drop below ground 535 mm (1'9")

Max. shoulder reach:

Left 2030 mm (6'8")

Right 2030 mm (6'8")

Max. bank cutting angle 90°

Cutting angle 29° ~ 77°



HYDRAULIC CONTROL UNIT

Hydraulic pumps: Tandem gear pump for work equipment and steering control.

Capacity . . . 77 ltr (20.3 U.S. gal) + 39 ltr (10.3 U.S. gal)
One gear pump for HYDROSHIFT transmission

Capacity 88 ltr. (23.2 U.S. gal)

Hydraulic motor: Orbit-type hydraulic motor of 28 HP (21 kW) output power is used for blade rotation.

Hydraulic cylinders: Double-acting piston type hydraulic cylinders: two for blade lifting, one for drawbar sideshifting, one for blade sideshifting, one for front wheel leaning, one for front wheel steering and two for frame articulation. Pilot check valves assure positive cylinder action (excluding a blade sideshift cylinder).

Control valves: 3-spool and 4-spool type control valves for work equipment controls. Relief valve built into control valves for sure control.

Relief valve setting:

- Work equipment . . . 200 kg/cm² (2844 PSI/19.6 MPa)
- Steering 175 kg/cm² (2489 PSI/17.2 MPa)
- Transmission 30 kg/cm² (427 PSI/ 2.9 MPa)



COOLANT & LUBRICANT CAPACITY (refilling)

- Coolant 34 ltr. (9.0 U.S. gal)
- Fuel tank 227 ltr. (60.0 U.S. gal)
- Engine 24 ltr. (6.3 U.S. gal)
- Transmission 34 ltr. (9.0 U.S. gal)
- Tandem case (total) 78 ltr. (20.6 U.S. gal)
- Final drive case 24 ltr. (6.3 U.S. gal)
- Hydraulic oil 30 ltr. (7.9 U.S. gal)



OPERATING WEIGHT (approximate)

Operating weight, including rated capacity of lubricant, coolant, full fuel tank, hydraulic equipment, operator, 3710 mm (12' 2") blade and 13.00-24-8PR (G-2) traction-type tires, and the standard equipment.

- On front wheels 3130 kg (6,900 lb)
- On rear wheels 7670 kg (16,910 lb)
- Total weight 10800 kg (23,810 lb)

STANDARD EQUIPMENT

ENGINE AND TRANSMISSION: 135 HP (101 kW) diesel engine. 24 V/5.5 kW starting motor. 24 V/25 A alternator. 2 x 12 V/110 Ah batteries. Corrosion resistor. Dry-type air cleaner with built-in centrifugal precleaner and automatic dust evacuator. Pusher type fan. Muffler. Hand throttle. Accelerator and inching pedals. HYDROSHIFT transmission.

METER AND GAUGES: Service meter. Water temperature gauge. Dust indicator. Battery discharge warning lamp. Engine oil pressure warning lamp. Parking brake warning lamp. Engine-preheat indicator.

MOLDBOARD: 3710 mm (12' 2") blade with two 6 feet cutting edges, reversible end bits. Hydraulic blade sideshift and manual tip control.

BRAKES: Foot-operated, internal expanding type service brakes with hydraulic booster. Hand operated, internal-expanding type parking brake.

TIRES: 13.00-24-8PR (G-2) traction-type tubed tires (front and rear)

OTHERS: Adjustable console. Adjustable seat. Horn. Panel lamp. Pilot check valves for blade lift, front wheel leaning, drawbar sideshift and frame articulation cylinders. Rear tow hitch. Operator guard.



DIMENSIONS

Unit: mm (ft.in)

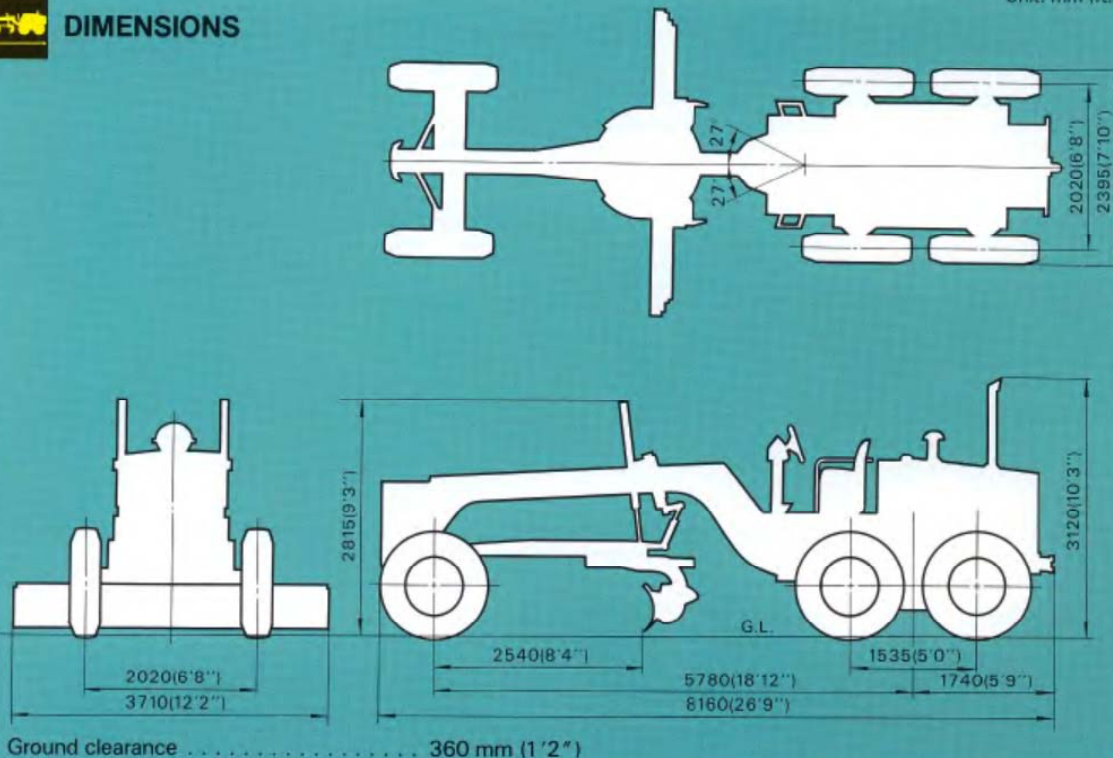

Attachment and optional equipment



Steel cab:

Additional weight . . . 310 kg (685 lb)
Installed height . . . 3335 mm (10' 11")

ROPS: Meets ISO 3471 and SAE J1040a ROPS standards.



Scarifier: This attachment digs up hard ground, like asphalt, old pavement and frozen surfaces, which are not removable by the blade. The number of teeth can be changed according to ground hardness.

Type . . . V-type, 2-stage adjustable, hydraulically controlled
Number of teeth 9
Digging width 1065 mm (3' 6")
Max. lift above ground 340 mm (1' 1")
Scarifier base 970 mm (3' 2")
Additional weight 660 kg (1,455 lb)
(11 tooth type scarifier is also available)



Rear-mounted ripper: Tool bar type. With hydraulically controlled raise and lower functions, this ripper can be used to dig out rocks or hard ground not removable by a scarifier.

No. of shanks 3 (5, max.)
Max. digging depth . . . 300 mm (1')
Max. lift above ground . 600 mm (2')
Max. digging width 1860 mm (6' 1")
Additional weight (includes push plate) 1095 kg (2,415 lb)

OPTIONAL EQUIPMENT

LIGHTING SYSTEM: Head lamps. Stop and tail lamps. Turn signal lamps (front and rear). Backup lamps. Working lamps. Licence-plate lamp. Warning beacon.

MIRRORS: Rear-view mirrors. Rear under-view mirror. Inside rear-view mirror.

ENGINE AND POWER TRAIN: Water separator. Large capacity alternator (35 A). Large capacity batteries (150 Ah). Application for dusty and sandy terrain (air cleaner extension, brushless alternator with hardened pulley, starting switch cover). Engine side covers. Rear side covers (for batteries). Air compressor (for tire inflation). Transmission-underguard. No-spin differential. Suction type fan. Additional fuel filter.

TIRES: 13.00-24-10PR, 13.00-24-12PR, 14.00-24-10PR, 14.00-24-12PR, 15.50-25-12PR traction type tubed or tubeless tires.

OPERATOR'S COMPARTMENT: ROPS cab. ROPS canopy. Steel cab. Canopy. Heater/defroster. Windshield wiper. Room lamp. Ash tray/cigar lighter. Seat belt.

METERS AND GAUGES: Speedometer. Engine oil pressure gauge. Fuel level gauge. Ammeter.

WORK EQUIPMENT: Scarifier (9 tooth or 11 tooth type). Front blade. Hydraulic blade tip control. 13' blade. 14' blade. Rear mounted ripper.

OTHERS: Front hydraulic piping covers. Double electric horn. Vandalism protection kit (fuel tank, radiator and hydraulic tank cap). Backup buzzer. Backup alarm. Fire extinguisher. Hydraulic jack.

This specification sheet may contain attachments and optional equipment that are not available in your area. Please consult your local Komatsu distributor for those items you may require. Materials and specifications are subject to change without notice.

KOMATSU